

NOTES: 1) INTERNAL 1000 LINE ENCODER, 4000 ENCODER COUNTS PER REVOLUTION.
INDEX LINE ON ENCODER WHEEL.

2) TIED INTERNALLY: TX :CN2 PIN 10 TO CN1 PIN 3
RX :CN2 PIN 11 TO CN1 PIN 4
+5V :CN2 PIN 12 TO CN1 PIN 2
GND :CN2 PIN 13 TO CN1 PIN 5

3) FOR HIGH SPEED OR HIGH TORQUE OPERATION USE POWER PIN A1 AND A2 ON CN1.

4) LED, SERVO-AMPLIFIER INDICATOR: RED = SERVO-AMPLIFIER OFF [DEFAULT STATE]
GREEN = SERVO-AMPLIFIER ON OR SERVO-ING IN PLACE
LED, TRAJECTORY INDICATOR: CLEAR = NOT IN CONTROLLED TRAJECTORY [DEFAULT STATE]
GREEN = IN CONTROLLED TRAJECTORY [CONTROLLED MOTION]

5) ALL DIMENSIONS ARE NORMAL UNLESS OTHERWISE SPECIFIED.

6) PINOUT IS FOR SMARTMOTORS NOT EQUIPPED WITH DRIVE ENABLE.
MOTORS EQUIPPED WITH DRIVE ENABLE 'DE' OPTION HAVE ALTERNATE PINOUT. REFER TO DRAWING FOR 'DE' SMARTMOTOR.

PART NO.
SV3416D

Peromatic GmbH Peromatic GmbH
Gubelstrasse 28 rue Confédération 29
CH-8050 Zürich CH-2300 La Chaux-de-Fonds
Fon +41-(0)43 300 60 60 Fon +41-(0)32 927 37 20
Fax +41-(0)43 300 60 79 Fax +41-(0)32 927 37 22
info@peromatic.ch
www.peromatic.ch

DRAWING REVISIONS

DWG REV	DESCRIPTION	DATE
1	PRODUCTION RELEASE	09/30/03
2	EDITED DIMENSION	06/25/04

CN1:CONNECTOR 1, 7 PIN COMBO D-SUB MALE CONNECTOR		
PIN#	NAME	FUNCTIONS
1	I/O G	G-Synchronization Pin
2	+5V OUT	+5V Out
3	RS232 TX	RS232-Transmit
4	RS232 RX	RS232-Receive
5	GND	Signal Ground
A1	PWR	Power,+20 to 48V dc
A2	PWR GND	Power Ground

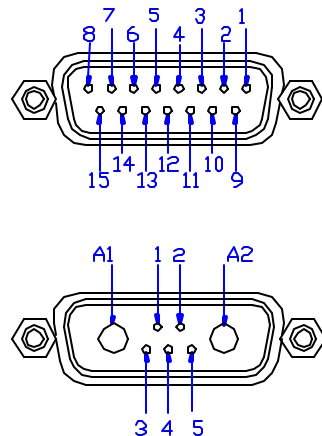

CN2: CONNECTOR 2, 15 PIN I/O D-SUB FEMALE CONNECTOR					
PIN#	NAME	SOFTWARE SELECTABLE FUNCTIONS			
		FUNCTIONS	FUNCTIONS	DIGITAL I/O (TTL)	ANALOG INPUT (10 bit)
1	I/O A	Ext Encoder A Input	Step Input	5V	0 to 5V
2	I/O B	Ext Encoder B Input	Direction Input	5V	0 to 5V
3	I/O C	Positive (Right) Limit Input		5V	0 to 5V
4	I/O D	Negative (Left) Limit Input		5V	0 to 5V
5	I/O E	AnInk Data	RS-485 Signal A	5V	0 to 5V
6	I/O F	AnInk Clock	RS-485 Signal B	5V	0 to 5V
7	I/O G	G-Synchronization Pin	RS-485 Adapter Flow Control Line	5V	0 to 5V
8	ENCA OUT	Encoder A Output			
9	ENCB OUT	Encoder B Output			
10	RS232 TX	RS232-Transmit			
11	RS232 RX	RS232-Receive			
12	+5V OUT	+5V DC Output			
13	GND	Signal Ground			
14	PWR GND	Power Ground			
15	PWR	Power, +20V to 48V dc			

NOTE: CURRENT CANNOT EXCEED 1AMPS ON PIN 14 AND PIN 15

LED, TRAJECTORY
CLEAR= NOT IN TRAJECTORY [DEFAULT STATE]
GREEN= IN A CONTROLLED TRAJECTORY (MOTION)

LED, SERVO-AMPLIFIER
RED=AMPLIFIER OFF [DEFAULT STATE]
GREEN=AMPLIFIER ON OR SERVO-ING IN PLACE

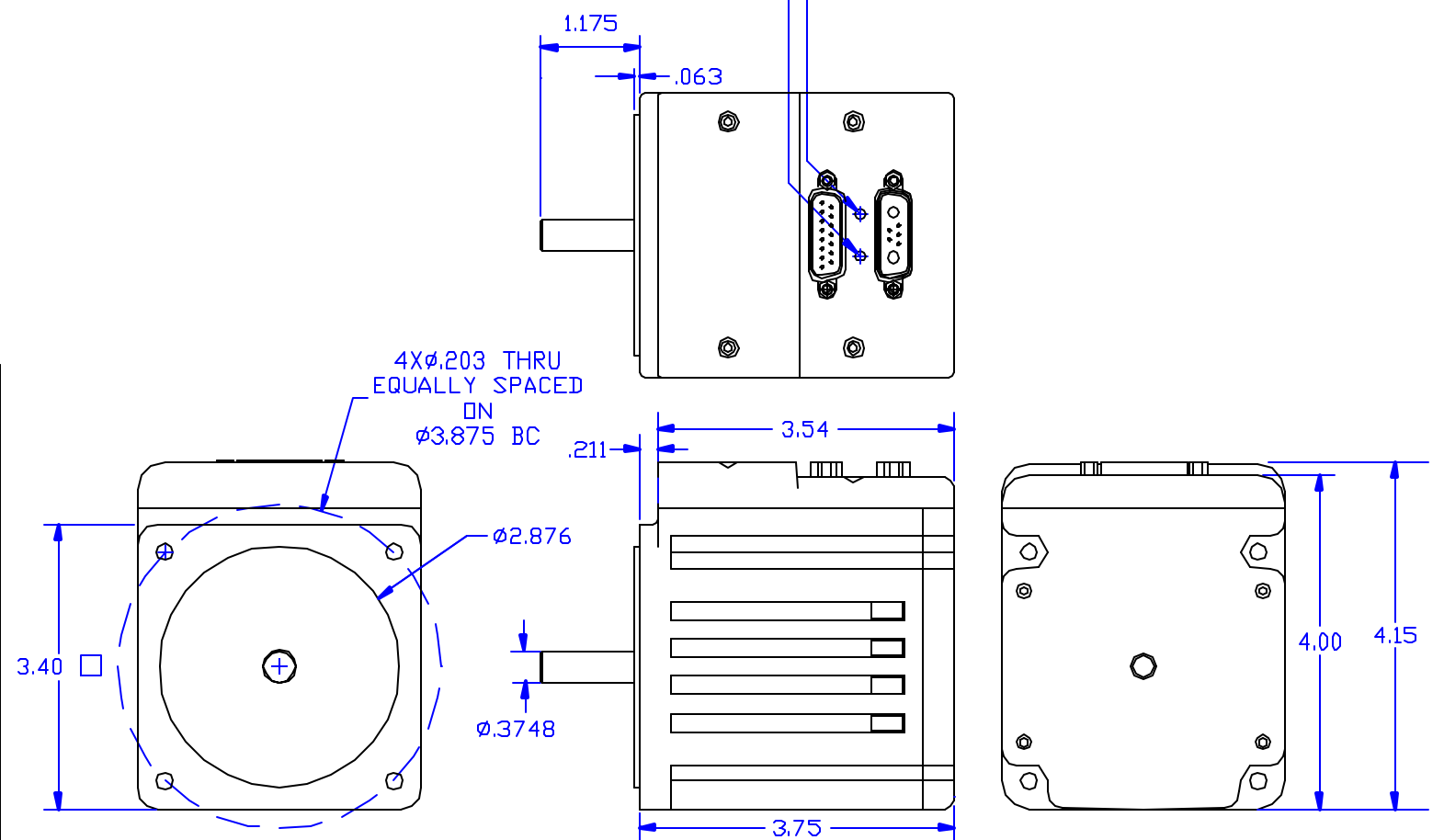

ITEM NO.	QTY	PART NO.	DESCRIPTION	MATERIAL SPECIFICATION
PARTS LIST				
UNLESS OTHERWISE SPECIFIED, DIMENSIONS & TOLERANCES ARE PER ANSI Y14.5M AND ARE IN INCHES. TOLERANCES ARE AS FOLLOWS: DECIMALS .XX± .XXX±		THIRD ANGLE PROJECTION		SERVIDA SV3416D
ANGLES ± .XXX±		DRAWN TC	DATE 2/13/04	
MATERIAL		SCALE NOT TO SCALE		SIZE B
FINISH BLACK ECOAT		COMPUTER GENERATED DRAWING		PART NO. SV3416D
SIMILIAR TO: SM3416D-FL		CAD FILE NAME SM3416D		DWG REV 2
SHEET 1 OF 1				

CONFIDENTIAL. THE INFORMATION CONTAINED HEREIN IS THE PROPRIETARY PROPERTY OF ANIMATICS CORPORATION, AND IS PROTECTED AS A TRADE SECRET. IT IS SUBMITTED FOR USE BY RECIPIENT ONLY FOR A BUSINESS PURPOSE AUTHORIZED BY ANIMATICS CORPORATION. ANY OTHER USE IS PROHIBITED. RECIPIENT AGREES TO KEEP SUCH INFORMATION CONFIDENTIAL.