

# Slip Ring Capsules (Compact)

## AC6379

### *Fiber Optic Rotary Joint and Slip Ring In various circuit configurations*

#### Description

The AC6379 is a unique rotary component that can combine both a single channel Fiber Optic Rotary Joint (FORJ) and an electrical slip ring in the same mechanical assembly. This unique assembly has a single multimode fiber optic channel and can also have 24 electrical circuits rated at 2 amperes each.

The FORJ features the same expanded beam optical system that is used in our field proven FO3585 design. This system minimizes insertion loss and rotational variation in the optical system.

The slip ring section of the assembly is based on technology used in the AC6355 unit. The assembly features precision ball bearing for long life and is rated for continuous operation at speeds up to 250 rpm. The electrical section uses a gold-on-gold contact technology, which provides the ultimate in performance for demanding applications.

#### Features

- Standard 24 circuit model with 2 amp circuits
- Precision ball bearing for long life
- Speeds up to 250 rpm continuous
- Compact size
- Sealed units available
- Metal housing available
- Transfer analog and digital signals
- Compatible with data bus protocols
- Single fiber optical rotary joint

#### Benefits

- Unique signal handling performance with minimal electrical circuit noise
- Tight packaging to fit in the most demanding space constraints
- Low torque to minimize system torque budget
- Rapid delivery

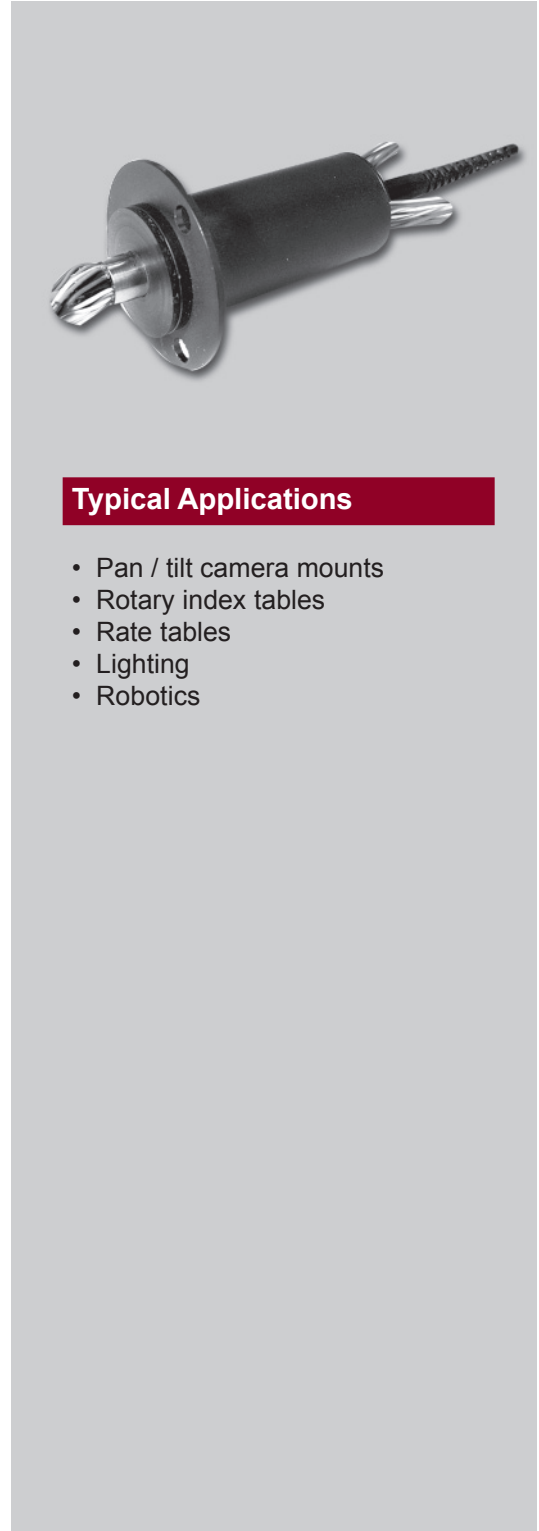

#### Typical Applications

- Pan / tilt camera mounts
- Rotary index tables
- Rate tables
- Lighting
- Robotics

Contact: Switzerland and Liechtenstein

Peromatic GmbH

Gubelstrasse 28  
rue Confédération 29  
info@peromatic.ch

CH-8050 Zürich  
CH-2300 La Chaux-de-Fonds  
www.peromatic.ch

Fon +41-(0)43 300 60 60  
Fon +41-(0)32 927 37 20

Fax +41-(0)43 300 60 79  
Fax +41-(0)32 927 37 22

# Slip Ring Capsules (Compact)

Specifications		Options
Operating Speed	250 rpm max. connectors	
Circuit Configurations	24 @ 2 amp	
Lead Length	24 inch (600 mm) optical and electrical +100/0 mm	• 48 inch (1200 mm)
Voltage	210 VDC	
Operating Temp.	-40°C to +80°C	
Contact Material	Gold-on-gold signal; silver	• Gold
Housing	Plastic	• Aluminum, black anodized
Lead Size / Type	Elec. 2 amp, 26 AWG Optical 62.5 / 125 nm multimode with 2 mm jackets	
Dielectric Strength	250 VAC @ 60 Hz, between each circuit and all other circuits	
Insulation Resistance	1000 megohms max tested @ 500 VDC	
Electrical Noise	60 milliohms max when tested @ 6VDC 50 milliamps when running @ 10 rpm	
Optical Insertion Loss	3.5 dB max. at 850 nm and 1300 nm	
Return Loss	-20 dB min.	
Optical Connectors	ST	• FC

\*Please note that the operational life of the unit is dependent upon rotational speed, environment and temperature.

2 amp leads will be color coded

Ring #	Color	Ring #	Color
1	BLK	19	BLK
2	BRN	20	BRN
3	RED	21	RED
4	ORN	22	ORN
5	YEL	23	YEL
6	GRN	24	GRN
7	BLU		
8	VIO		
9	GRY		
10	WHT		
11	WHT-BLK		
12	WHT-BRN		
13	WHT-RED		
14	WHT-ORN		
15	WHT-YEL		
16	WHT-GRN		
17	WHT-BLU		
18	WHT-VIO		

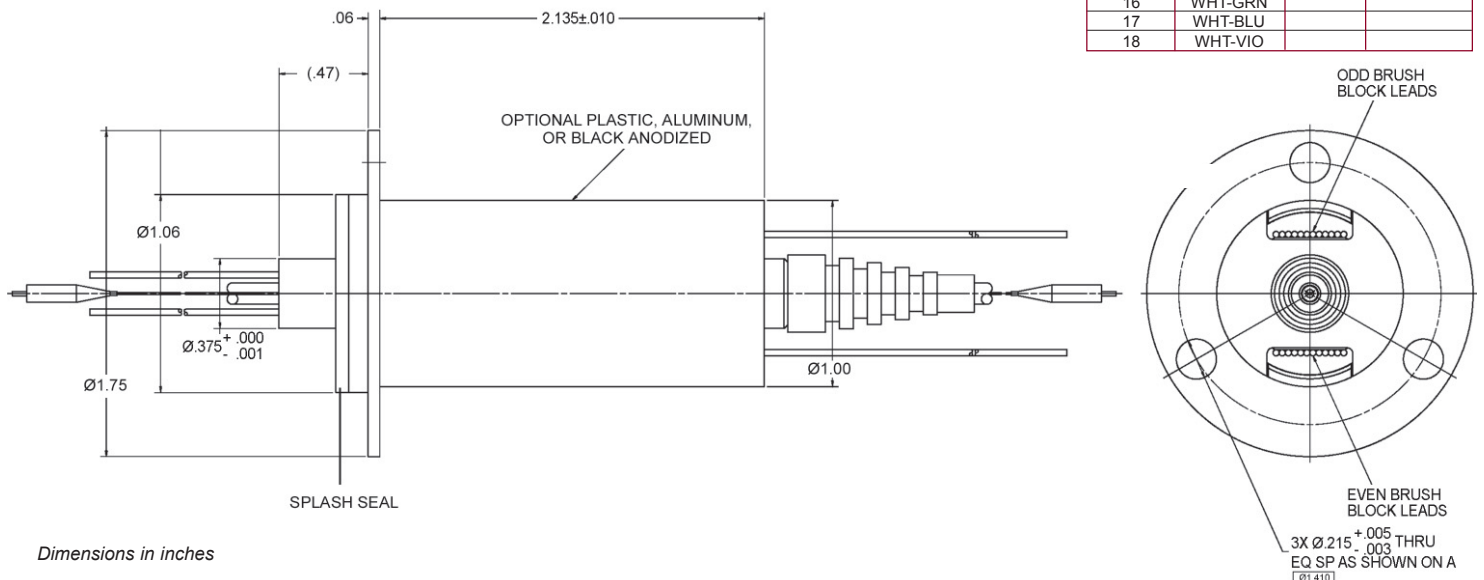

Dimensions in inches