

Silencer™ Series Brushless Controllers

TYPICAL APPLICATIONS

Control of Brushless Motors for:

- Medical pumps and blowers
- Air-handling equipment
- Packaging and printing products
- Semiconductor handling and insertion machines
- Industrial automation equipment
- Office automation and equipment

FEATURES

- 2-quadrant speed controllers for electronically commutating three-phase brushless motors with Hall sensors, which are arranged offset at 120 electrical degrees
- Speed of the motor is preset by means of either an internal or an external potentiometer
- Maximum constant current can be adjusted via an on-board potentiometer
- Direction of rotation of the motor can be preset by means of the direction control input. The controller output stage can be activated and deactivated by means of the disable control input
- Controller is safeguarded against heat overload by means of an internal thermal cutoff
- Controller output stage has been constructed using POWER-MOSFET technology, resulting in very high efficiency

BENEFITS

- Compact packaging minimizes space demands
- Matched drives and motors from a single supplier
- Complete system testing provides high reliability
- Terminal block connections for ease of wiring
- Multiple methods of speed control
 - Input voltage
 - Internal potentiometer
 - External potentiometer
 - External voltage reference

BDP-Q2-50-10 **BDP-Q2-20-10** 2-quadrant speed controller for brushless motors

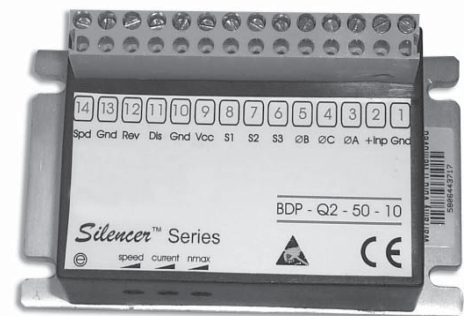

Silencer™ brushless controllers are available in a variety of voltage and current ratings. Their compact packaging minimizes space demands. All controllers have generous terminal blocks to facilitate ease of wiring.

Silencer drives are compatible with Silencer Series Brushless DC Motors. Silencer motors are available in sizes 12, 17, 23, 28, 34 and 42 in standard frames with 1.2" to 4.15" diameters. They offer speeds up to 20,000 rpm and continuous torques ranging from 1.2 to 519 oz-in. Standard options include gearheads, resolvers and encoders.

If you have questions about Silencer drives or would like to speak to an applications engineer, please call us or visit our web site.

Peromatic GmbH

Gubelstrasse 28 CH-8050 Zürich
rue Confédération 29 CH-2300 La Chaux-de-Fonds
info@peromatic.ch www.peromatic.ch

Fon +41-(0)43 300 60 60 Fax +41-(0)43 300 60 79
Fon +41-(0)32 927 37 20 Fax +41-(0)32 927 37 22

BDP-Q2-50-10, BDP-Q2-20-10 SPECIFICATIONS

Electrical Data	BDP-Q2-50-10	BDP-Q2-20-10
Operating voltage -+input and Gnd Residual voltage < 5%	20 - 50 VDC	12 - 20 VDC
Maximum constant current (adjustable)*	10A	10A
Supply voltage for Hall switches	6 V / 20 mA	

*At higher input voltages, additional heat-sinking may be required for maximum current.

Inputs

- Direction of rotation – (REV) open collector / TTL / CMOS / switch
- Disable output stage – (DIS) open collector / TTL / CMOS / switch

Temperature Range

- Storage -104 to 185° F (-40 to +85° C)
- Operation -50 to 113° F (-10 to +45° C)

Moisture Range

20 to 80% non-condensed

Mechanical Data	BDP-Q2-50-10	BDP-Q2-20-10
Weight	4.93 oz	4.93 oz
	140 gm	140 gm
Dimensions - (L x W x H) - 2.17 x 3.70 x 1.54 in (55 x 94 x 39 mm)		
Mounting - 4 x M3 with a distance between holes of 1.54 x 3.43 in (39 x 87 mm)		
Drill Diameter - 4.0 mm - (4) places		

Termination Table

Terminal #	Nomenclature	Description
1	GND	Gnd for Supply Voltage
2	Positive Input	Positive Supply Voltage
3	Phase A	Motor Phase A
4	Phase C	Motor Phase C
5	Phase B	Motor Phase B
6	S3	Hall Switch #3
7	S2	Hall Switch #2
8	S1	Hall Switch #1
9	VCC	Supply for Hall Switches
10	GND	Gnd for Hall Switches
11	DIS	Control Input - Disable
12	REV	Control Input - Reverse
13	GND	Gnd for Dis and Rev
14	SPD	Set value input for speed

Outline Drawing - Three Views

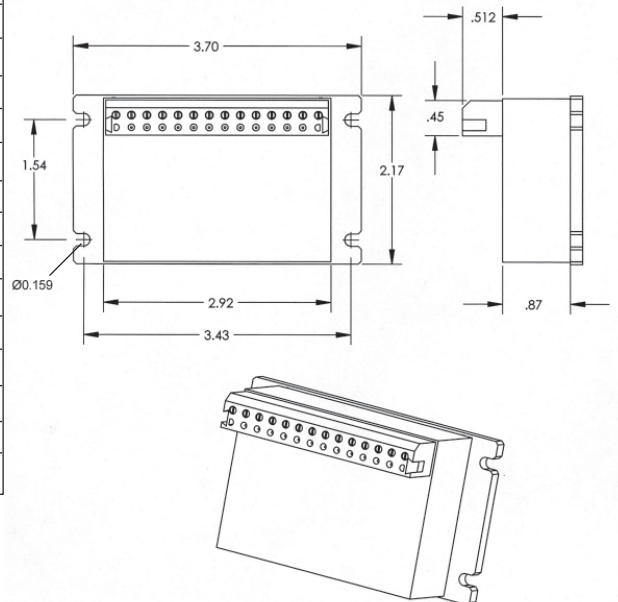

Peromatic GmbH

Gubelstrasse 28
rue Confédération 29
info@peromatic.ch

CH-8050 Zürich
CH-2300 La Chaux-de-Fonds
www.peromatic.ch

Fon +41-(0)43 300 60 60
Fon +41-(0)32 927 37 20

Fax +41-(0)43 300 60 79
Fax +41-(0)32 927 37 22