

## FO197

### *Fiber optic rotary joint*

#### **Description**

The FO197 is a single-pass, multimode fiber optic rotary joint (FORJ). It is passive and bidirectional, and allows the transfer of any type of optical signal across rotational interfaces.

The FO197 fiber optic rotary joint can be combined with our electrical and / or fluid slip rings, providing a single, compact package for optical signals, electrical power and fluid transfer.

The FORJ can be assembled with pigtail lengths tailored to the customer's application or installed with connector bushings (ST or FC). Housing, mounting flange and drive features can also be customized to meet the customer's requirements.

#### **Features**

- Provides rotary coupling for a multimode fiber link
- Passive bidirectional device
- Can be combined with our electrical slips and fluid unions
- Alternative drive coupling and mounting arrangements are available (consult factory for specification details)
- Connectorized interfaces, for easy fiber cable replacement
- Can be integrated into existing slip ring designs
- Stainless steel, aluminum or anodized aluminum housing
- Rugged design
  - MIL-STD-167-1 ship vibration
  - MIL-STD-810D functional shock (40 g)

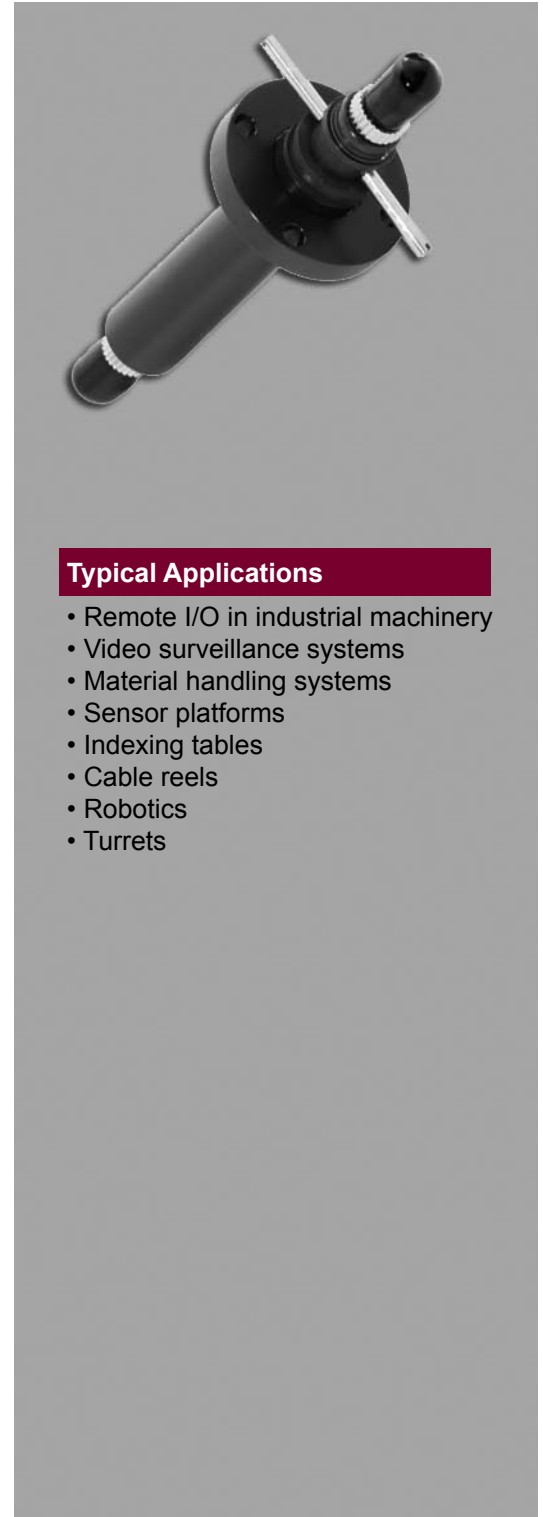

#### **Typical Applications**

- Remote I/O in industrial machinery
- Video surveillance systems
- Material handling systems
- Sensor platforms
- Indexing tables
- Cable reels
- Robotics
- Turrets

# Fiber Optic Rotary Joints (FORJ)

Specifications		
Fiber Size (Microns)	50/125, 62.5/125, 100/140 or 200/230	
Insertion Loss	Typical < 1.5 dB	Maximum < 3.0 dB
Rotation Variation	Typical < 0.5 dB	Maximum < 1.0 dB
Back Reflection	Typical 22 dB	18 dB Minimum
Wavelengths	850, 1300 or 1550 nm. Consult factory for multi-wavelength applications.	
Rotational Speeds	To 1000 rpm. Higher rotational speeds should be discussed with the factory.	
Temperature	-40 to +60 deg C (dry version). Consult factory for extended range.	
Dispersion	< 10 picoseconds (calculated)	
Exterior Surfaces	Stainless steel, aluminum or anodized aluminum	
Vibration	Tested to MIL-STD-167-1 (ships)	
Shock	Tested to MIL-STD-810D	
Terminations	ST or FC connector receptacles or pigtailed with cable and connectors to meet customer's requirements	
Pressure	Up to 10000 psi (69,000 kPa) for fluid filled version*	
Pigtail Length	As required	

\* Fluid filled version is slightly larger than shown below.

## Hybrid Units

Can be combined with electrical and fluid slip rings.

## Mounting

See diagrams for details. Customized mounting flanges also available.

## Pressure

Optional fluid-filled version for pressure compensation (in a slightly larger housing than shown).

## Exterior Surfaces

Stainless steel, aluminum or anodized.

## Terminations

ST or FC connector receptacles or pigtailed with cable and connectors to meet customer's requirements.

## FO197 Dimensions

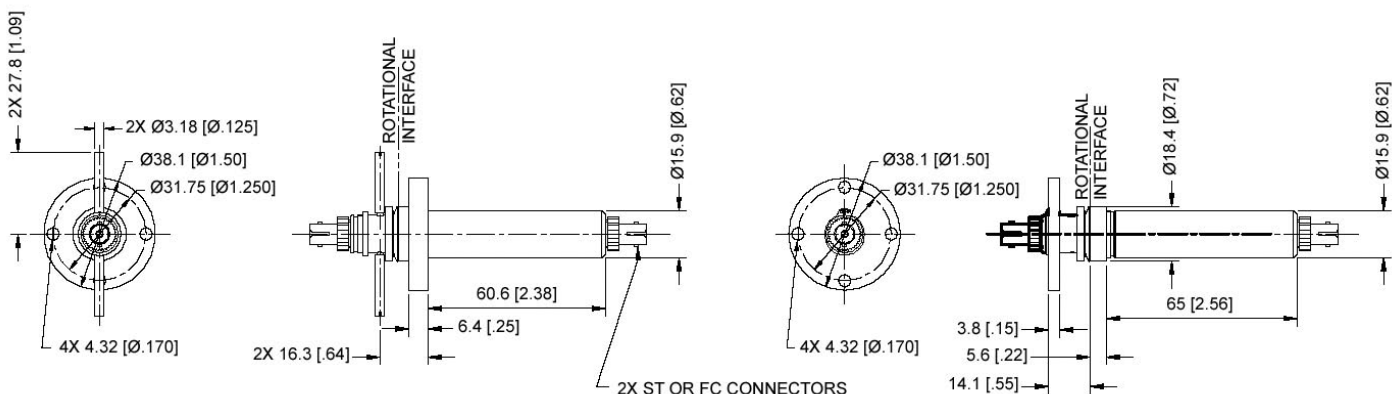

**Body Mounting Arrangement (B)**

**Shaft Mounting Arrangement (S)**